

Fact Sheet

CWFmaxx 6000

BIZERBA

Our solution for food processing companies ... dynamic checkweigher CWFmaxx was specially designed for this industry. Thanks to its sophisticated design it impresses in terms of hygiene and easy cleaning.



More information
High performance
with a wide range of
solutions and options.

Specifications	Facts	Details
Weighing data	Weighing range: 6000 g Division value d: 1 - 2 g Verification scale interval e: 1 - 2 g Minimum load: 150 g	3000 6000 g 1 g 2 g 1 g 2 g 150 g
Performance	max. throughput: 152 - 329 packages per min. max. belt speed: 120 m/min min. belt speed: 5 m/min	depends on the length of the weighing conveyors
Device design / material	Stainless steel	1.4301
Display / control panel	12.1" SVGA color touch screen	
Interfaces	USB, EDP 1, 8 inputs, 8 outputs, Ethernet	EDP 1 (RS 232 or RS 422 or TTY)
Protection class	Conveying conveyor Switching cabinet Display unit	IP65 IP65 IP65
Conveying	Conveying direction Conveying height	right to left left to right 750 - 1150 mm
Conveyors	Conveyor width: 225 - 400 mm Conveyor lengths: Weighing conveyor length: 325 - 750 mm Infeed conveyor length: 325 - 750 mm Ejecting conveyor length: 325 - 1500 mm Belt colors: white and blue Roller diameter: 32 mm Conveyor frame and quick belt release system	225, 300, 400 mm lengths always in wheelbase: 325, 400, 500, 600, 750 mm 325, 400, 500, 600, 750 mm 325, 400, 500, 600, 750, 1000, 1250, 1500 mm white as standard and blue as an option available Aluminum rollers, hard coated surface
Environmental conditions	Operating temperature Humidity	+0 °C to +40 °C 20 - 90% non-condensing
Energy supply	Supply voltage Power consumption Pompressed-air supply	100-240 V; 50/60 Hz 500-750 VA 6 bar
Software licenses	STATISTICS WEIGHT_CLASSES	to generate statistics to classify more than three products
Software versions	Software Codepage Software UNICODE	data communication (texts & strings) data communication (texts & strings) in UTF-8 code
More features	Article memory Weight classes Remote maintenance Web interface Sending of status e-mails	100000 80

Options	Facts	Details
Metrological approved according to OIML R 87	Control of prepackaged products	The checkweigher are metrological approved according to the accuracy class XIII (1) and suitable for German prepack regulations.
Metal detector	Integrated metal detector Metal detector conveyor length	Operation of the metal detector is done from the display of the checkweigher. 750 1000 mm
Control panel	7" color display with membrane keyboard	WVGA (800x480)
Separation conveyor	325 400 500 600 750 mm	lengths always in wheelbase
Ejecting systems	Air blast ejector Pusher	further separating systems on request as a project
Reject bins	Stainless steel Dimensions (L x D x H) Reject bin full control Reject confirmation Lock for reject bin door Reject bin door status	150 200 300 400 x 300 x 750 mm, opening 200 mm 250 350 500 x 310 410 x 750 mm, opening 250 mm light barrier 1 light barrier or 4 light barriers available as bar or lock the system will stop after a set time when the reject bin door keeps opened
Log strip printer	Mounted on the switching cabinet	including LINE_PRINTER license and serial interface
Emergency stop	Emergency stop with belt shutdown Emergency stop with pneumatic & belt shutdown	mounted to main column, turns off belt drives turns off pneumatic system and conveyors
Signal lamps	2-colored 3-colored	red = fault, green = device okay red = fault, yellow = stop, green = belts running
Emergency operation function	The conveyor belts of the checkweigher can be started manually, even if the operating and control unit have failed.	To secure the production flow, the belts run (without weighing function). Operation via extra module in the switching cabinet with adjustable belt speeds.
Tendency control kit	incl. license Tendency Control and relays	
Line integration kit	Standard: 3 outputs via relays and 1 input	
Package flow control	with 1 light barrier	
Draft shield	Top	reduces disturbing influences by airflow
Guide rails	Available for all lengths of belts	
Belt transition	Available for all widths of belts	closes gaps between belt bodies
Compressed air monitoring	The system will stop at drop in air pressure	
Software licenses	BRIDGE+MC_BUFFER EICHFÄHIG_X1 ETHERNET ONLINE SOFTCONTROL TENDENCY CONTROL LINE_PRINTER	for buffering data in the event of LAN / pc failure according to OIML R 87, incl. conformity evaluation ethernet connection via TCP / IP communication via the Gx-Net via ETHERNET to operate from a second workplace for the regulation of filling machine (without relay) is required for external printer

Infographic



Symbols



329
packages/
minute



Protection
class IP65



Unicode



e
(metrological
approved)



Stainless
Steel



Strain gauge

Dimensions

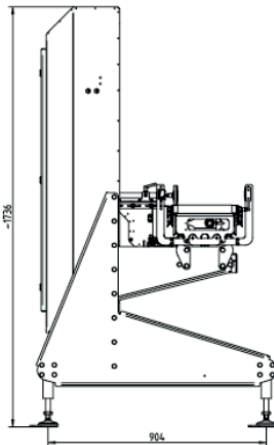
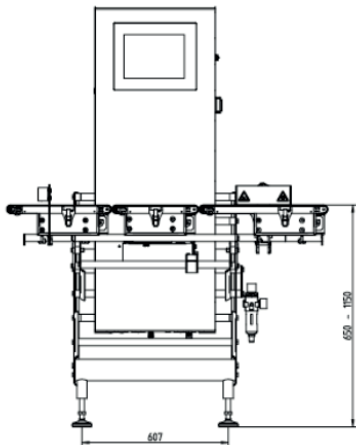

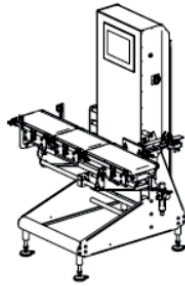
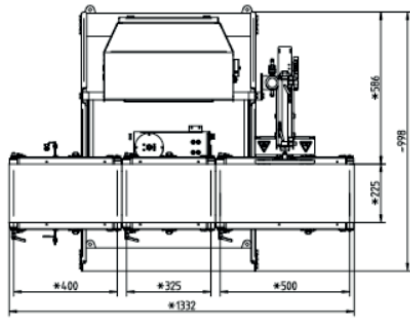

Bizerba SE & Co. KG
Wilhelm-Kraut-Straße 65
72336 Balingen
Germany
T +49 7433 12-0
F +49 7433 12-2696
marketing@bizerba.com

www.bizerba.com