

BIZERBA

closer to your business

Powerful performance even in continuous operation ...

... Manual Slicers VS 12 Ee / VS 12 W Ee:
Fast – robust – accurate to within a gram

 **Emotion**
Efficient in energy



VS 12 Ee

VS 12 C W Ee



The deli slicer VS 12 Ee offers a multitude of applications. In addition, the VS 12 W Ee provides you with a checkweigher. The product can be perfectly sliced and weighed in a single working step. This accelerates operation considerably and increase sales of specific products by selling larger quantities.

Ease of handling

- Smooth-running carriage thanks to carriage guide bearings located securely inside the motor housing
- Slip grooves in the carriage rear wall ensure smooth and easy gliding of the product
- The ergonomically optimised remnant holder allows
 - feeding of the product to the blade with one hand while at the same time guiding the product along the rear wall of the carriage
 - slicing to the very last slice without discomfort in the hand that guides the carriage
- Setting of slice thickness, to fine setting option
- Improved hygiene thanks to easily removable sharpener

Quality and Safety

- Highest energy efficiency and low cost of ownership due to Emotion technology
- Closed blade guard with additional handle for easy removal

- Maximum safety thanks to emergency shut-off (on /off) and restart lockout (in the event of power failure)
- Quiet, maintenance-free blade drive
- Remnant holder to minimise product waste due to scraps or first slice
- Adjustable stop plate and product support in the lower section of blade
- Minimised risk for operator thanks to protected cutting area during sharpening

Cleaning and hygiene

- Quick disassembly of parts that can be removed for cleaning
- Remnant holder with magnet lock for quick assembly/disassembly
- Compact design with closed mounting frame
- Swivel-mounted deflector with smooth edges to avoid dirt buildup
- Easy access to all parts
- Membrane keyboard protected against dripping water
- Comfortable to clean thanks to optional Ceraclean finish

■ Protection type		IP 33	
■ Current type			
1-phase AC	Voltage	220-240 V	100-120 V
	Frequency	50/60 Hz	60 Hz
	Nominal current consumption	1.0 A	1.9 A

	VS 12 Ee	VS 12 W Ee
■ Outer dimensions	625 x 555 x 488 mm / 24.6" x 21.9" x 19.21"	625 x 560 x 488 mm / 26.6" x 22.0" x 19.21"
■ Installation area	520 x 430 mm / 20.4" x 16.9"	520 x 430 mm / 20.4" x 16.9"
■ Work area	672 x 740 mm / 26.5" x 29.1"	672 x 745 mm / 26.5" x 29.3"
■ Blade diameter	330 mm / 13"	330 mm / 13"
■ Blade speed	208 U/min (208 rpm)	208 U/min (208 rpm)
■ Max. product size	round Ø, 225 mm / 8.9"	round Ø, 225 mm / 8.9"
	rectangular, (B x H) 260 x 175 mm / 10.2 x 6.9"	rectangular, (B x H) 260 x 175 mm / 10.2 x 6.9"
■ Setting of slice thickness		
Continuous	0 - 24 mm / 0 - 0.94"	0 - 24 mm / 0 - 0.94"
Fine setting	0 - 3 mm / 0 - 0.12"	0 - 3 mm / 0 - 0.12"
■ Weight	approx. 40 kg / 88.2 lbs	approx. 43 kg / 94.8 lbs
■ Packaging data		
Total weight	Box (L x B x H) 830 x 700 x 690 mm / 32.7 x 27.6 x 27.17"	approx. 49 kg / 108 lbs
■ Optional extras	Product fixation, bias slicer, Ceraclean surface finish, Ceraclean blade, cheese blade, bread blade.	
	Further information on request.	

VS 12 W scales

■ Checkweigher	Not metrologically approved
■ Weighing range	0 - 3000 g / 0 - 6.6 lbs
■ Digit interval	2 g / 0.004 lbs
■ Tare	100 %
■ Load plate (W x D)	260 x 245 mm / 10.2 x 9.6"

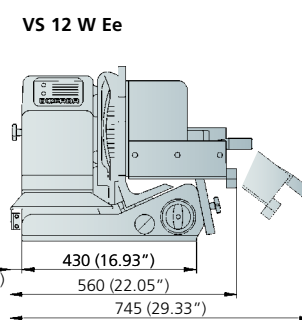
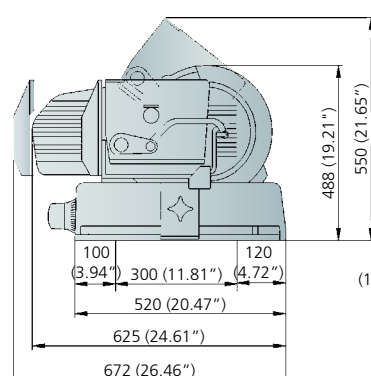
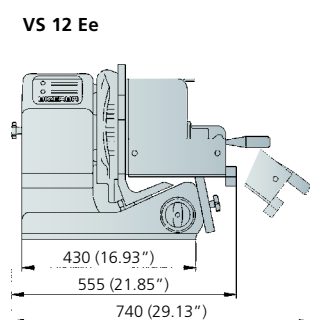
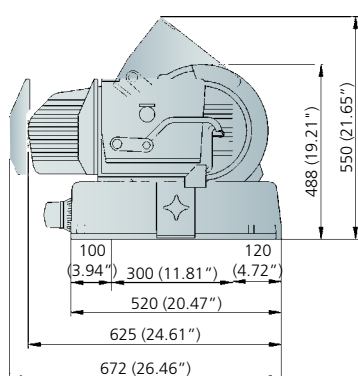

Members of the Bizerba Group

Bizerba GmbH & Co. KG
 Wilhelm-Kraut-Straße 65
 72336 Balingen
 Germany
 Tel. +49 7433 12-0
 Fax +49 7433 12-2696
 marketing@bizerba.com
 www.bizerba.com

Bizerba UK Limited
 2-4 Erica Road
 Stacey Bushes
 Milton Keynes
 Buckinghamshire
 MK12 6HS
 U.K.
 Tel. +44 1908 682740
 Fax +44 1908 682777
 sales@bizerba.co.uk

Bizerba USA Inc.
 1804 Fashion Court
 Joppa, MD 21085
 USA
 Tel. Office +1 732 565-6000
 Tel. Service +1 732 565-6001
 Fax +1 732 819-0429
 us.info@bizerba.com
 www.bizerbausa.com

Bizerba Canada Inc.
 2810 Argentinia Road #9
 Mississauga,
 Ontario L5N 8L2
 Canada
 Tel. +1 905 816-0498
 Fax +1 905 816-0497
 ca.info@bizerba.com
 www.bizerba.ca

Bizerba (Shanghai) Weigh Tech
 & Systems Co.Ltd.
 D-3, Qianpu Road, Shuhui Real Est.Park
 East New Area of Songjiang, Ind.Zone
 201611 Shanghai
 China
 Tel. +86 (21) 67 60 09 99
 Fax +86 (21) 67 60 09 98
 marketing.china@bizerba.cn
 www.bizerba.cn