

# BIZERBA

... closer to your business

## Powerful performance even in continuous operation ...

... Manual Slicers VS 12 / VS 12 W:

Fast – robust – accurate to within a gram



VS 12



VS 12 C W

The deli slicer VS 12 offers a multitude of applications. In addition, the VS 12 W provides you with a checkweigher. The product can be perfectly sliced and weighed in a single working step. This accelerates operation considerably and increase sales of specific products by selling larger quantities.

### Ease of handling

- Smooth-running carriage thanks to carriage guide bearings located securely inside the motor housing
- Slip grooves in the carriage rear wall ensure smooth and easy gliding of the product
- The ergonomically optimised remnant holder allows
  - feeding of the product to the blade with one hand while at the same time guiding the product along the rear wall of the carriage
  - slicing to the very last slice without discomfort in the hand that guides the carriage
- Setting of slice thickness, to fine setting option
- Improved hygiene thanks to easily removable sharpener

### Quality and Safety

- Closed blade guard with additional handle for easy removal
- Maximum safety thanks to emergency shut-off (on /off) and restart lockout (in the event of power failure)
- Quiet, maintenance-free blade drive

- Remnant holder to minimise product waste due to scraps or first slice
- Adjustable stop plate and product support in the lower section of blade
- Minimised risk for operator thanks to protected cutting area during sharpening

### Cleaning and hygiene

- Quick disassembly of parts that can be removed for cleaning
- Remnant holder with magnet lock for quick assembly/disassembly
- Compact design with closed mounting frame
- Swivel-mounted deflector with smooth edges to avoid dirt buildup
- Easy access to all parts
- Membrane keyboard protected against dripping water
- Comfortable to clean thanks to optional Ceraclean finish

<b>Protection type</b>		IP 33		
<b>Current type</b>				
1-phase AC	Voltage*	230 V	120 V	220 V
	Frequency	50 Hz	60 Hz	60 Hz
	Nominal current consumption	1.8 A	3.3 A	1.7 A
3-phase AC	Voltage*	230/400 V		
	Frequency	50 Hz		
	Nominal current consumption	1.2/0.68 A		

\*Various voltages depending on country, further information on request

	<b>VS 12</b>	<b>VS 12 W</b>
<b>Outer dimensions</b>	625 x 555 x 432 mm / 24.6" x 21.9" x 17.0"	625 x 560 x 432 mm / 26.6" x 22.0" x 17.0"
<b>Installation area</b>	520 x 430 mm / 20.4" x 16.9"	520 x 430 mm / 20.4" x 16.9"
<b>Work area</b>	672 x 740 mm / 26.5 x 29.1"	672 x 745 mm / 26.5" x 29.3"
<b>Blade diameter</b>	330 mm / 13"	330 mm / 13"
<b>Blade speed</b>	266 U/min (266 rpm)	266 U/min (266 rpm)
<b>Max. product size</b>	round Ø, 225 mm / 8.9" rectangular, (B x H) 260 x 175 mm / 10.2 x 6.9"	round Ø, 225 mm / 8.9" rectangular, (B x H) 260 x 175 mm / 10.2 x 6.9"
<b>Setting of slice thickness</b>		
Continuous	0 - 24 mm / 0 - 0.94"	0 - 24 mm / 0 - 0.94"
Fine setting	0 - 3 mm / 0 - 0.12"	0 - 3 mm / 0 - 0.12"
<b>Weight</b>	approx. 40 kg / 88.2 lbs	approx. 43 kg / 94.8 lbs
<b>Packaging data</b>		
Total weight	approx. 49 kg / 108 lbs	approx. 52 kg / 114.6 lbs
<b>Optional extras</b>	Product fixation, bias slicer, Ceraclean surface finish, Ceraclean blade, cheese blade, bread blade. Further information on request.	

**VS 12 W scales**

<b>Checkweigher</b>	Not metrologically approved
<b>Weighing range</b>	0 - 3000 g / 0 - 6.6 lbs
<b>Digit interval</b>	2 g / 0.004 lbs
<b>Tare</b>	100 %
<b>Load plate (W x D)</b>	260 x 245 mm / 10.2 x 9.6"

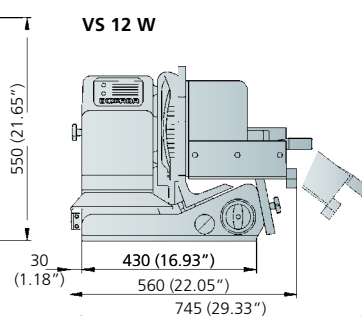
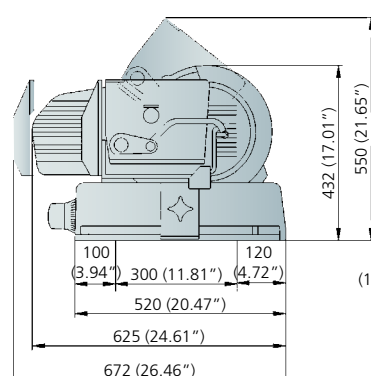
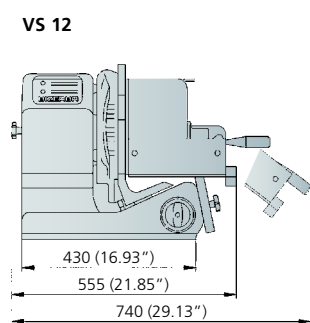
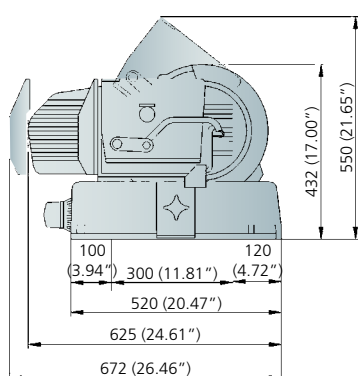

**Members of the Bizerba Group**

Bizerba GmbH & Co. KG  
Wilhelm-Kraut-Straße 65  
72336 Balingen  
Germany  
Tel. +49 7433 12-0  
Fax +49 7433 12-2696  
marketing@bizerba.com  
www.bizerba.com

Bizerba UK Limited  
2-4 Erica Road  
Stacey Bushes  
Milton Keynes  
Buckinghamshire  
MK12 6HS  
U.K.  
Tel. +44 1908 682740  
Fax +44 1908 682777  
sales@bizerba.co.uk

Bizerba USA Inc.  
1804 Fashion Court  
Joppa, MD 21085  
USA  
Tel. Office +1 732 565-6000  
Tel. Service +1 732 565-6001  
Fax +1 732 819-0429  
us.info@bizerba.com  
www.bizerbausa.com

Bizerba Canada Inc.  
2810 Argentia Road #9  
Mississauga,  
Ontario L5N 8L2  
Canada  
Tel. +1 905 816-0498  
Fax +1 905 816-0497  
ca.info@bizerba.com  
www.bizerba.ca

Bizerba (Shanghai) Weigh Tech  
& Systems Co.Ltd.  
D-3, Qianpu Road, Shuhui Real Est.Park  
East New Area of Songjiang, Ind.Zone  
201611 Shanghai  
China  
Tel. +86 (21) 67 60 09 99  
Fax +86 (21) 67 60 09 98  
marketing.china@bizerba.cn  
www.bizerba.cn